



vulcano grey

Terracotta façades

rainscreen cladding – back-ventilated – heat-insulated



MADE IN GERMANY

German quality

As market leader, the MOEDING Keramikfassaden GmbH sets global standards in the curtain wall, back-ventilated and heat-insulated tile façade segment with ALPHATON® and LONGOTON®. As a 100% subsidiary of Girnglhuber GmbH, located at Marklkofen (Lower Bavaria) with our 250 employees, we guarantee the highest quality in design and manufacture ever produced in Germany. With always the goal in mind: to provide architects and builders with custom solutions in every form – for creative features in innovative façade design. This is underlined by our sound practical advice and our numerous distinctions. More at www.moeding.de .

German Institute of Construction Engineering (Deutsches Institut für Bautechnik)



General building inspectorate approval. Curtain wall, back-ventilated outer wall cladding “ALPHATON® Gen 95” and “ALPHATON® Gen 06”.

CSTB



“ALPHATON®” is certified for the French market and satisfies all building regulations there.



CWCT

The “ALPHATON®” has been tested and certified for its compliance with the building regulations in the UK.

Quality



Quality assurance on the façade elements is done by our own continuous monitoring as well as regular external monitoring by test institutes according to the standards of the certifying body “Güteschutz-Ziegel für das Land Bayern e.V.”. General building inspectorate approval No. Z-33-1-531 for curtain wall, back-ventilated outer wall cladding with “ALPHATON®” tiles.

Contents

ALPHATON® terracotta façade	05
ALPHATON® façade system	
ALPHATON® Gen.06	06
ALPHATON® L ²	14
Function	22
Building physics	24
Planning	26
Design	28
Materials and colours	30
Surfaces	31
Sunscreen and blinds	34
Formats	36
References new construction	38
References renovation	52



Duisburg Inner Harbour, Pier 1
Architects: Reichel + Stauth, Brunswick
Colour: oxide red antique
Surface: standard

ALPHATON® terracotta façade

In the early 80s, the architect Prof. Thomas Herzog had the idea about a back-ventilated terracotta façade and, together with the roof tile manufacturer Möding, developed it into a system.

This original idea turned into the Argeton façade, which was produced for over 20 years in Möding and was used on façades covering thousands of square metres.

After being taken over by Girng Huber GmbH in 2001, MOEDING Keramikfassaden GmbH expanded the product range, developed the façade system further and consequently stopped using the Argeton product name. An independent sales company, MOEDING Keramikfassaden GmbH, was established.

Argeton turned into ALPHATON®.

Over recent years a new façade system has gained in maturity. ALPHATON® Gen. 06 is the result of this successive development work.

As an innovation leader, we are now proud to proclaim that the term "MOEDING ALPHATON® façade" is deemed as the quality feature in the sector for back-ventilated terracotta façades.



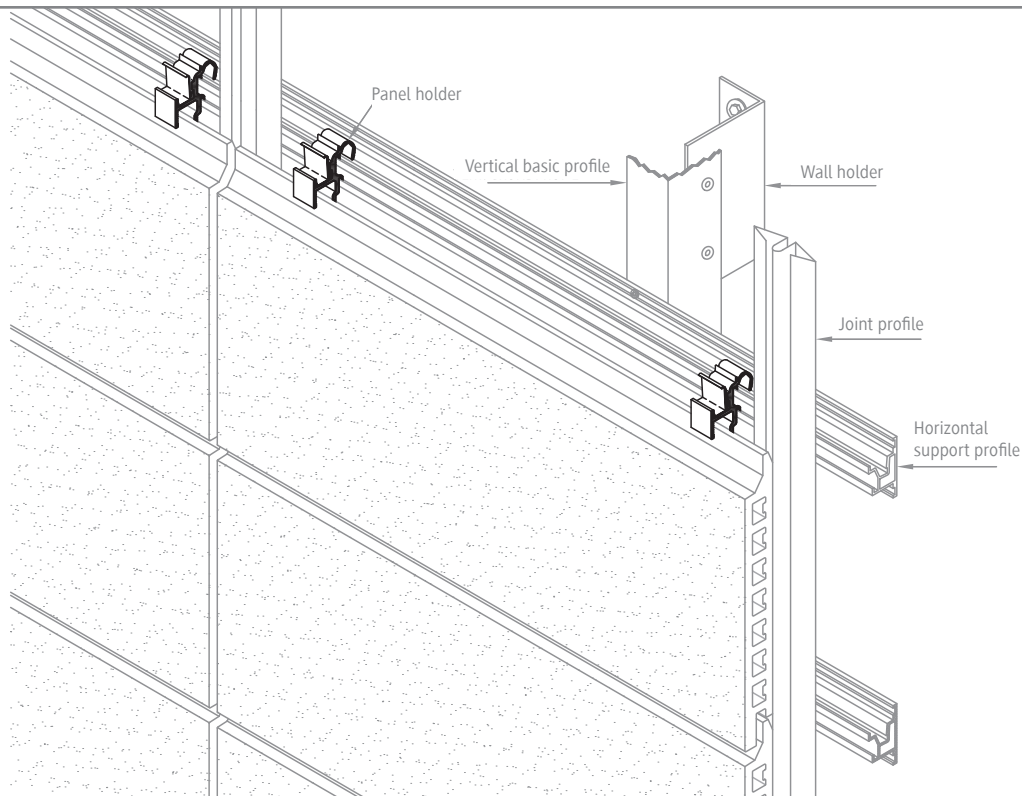

ALPHATON® façade system

The ALPHATON® façade system is made out of four simple basic components:

- Terracotta tiles
- Tile holders
- Horizontal support profile
- Joint profile

ALPHATON® terracotta tiles

The extruded MOEDING ALPHATON® terracotta tiles are produced mainly from domestic clay and are fully imbued with colour. Due to the very high firing temperature and the long firing period, intensive colours and the best strength are achieved.

The terracotta tiles are double-walled and 30 mm thick. The breaking loads of the ALPHATON® panel are therefore many times higher than with single-walled panels. The shape of the panel holders also contributes to the stability of the whole façade design. The panel holders are formed in such a way that frontal forces are transferred to the whole tile thickness and dissipate into the substructure.

The specifications for this are the so-called ball-throw test and the CWCT accreditation, which is generally applicable in England and is already part of the standards there.

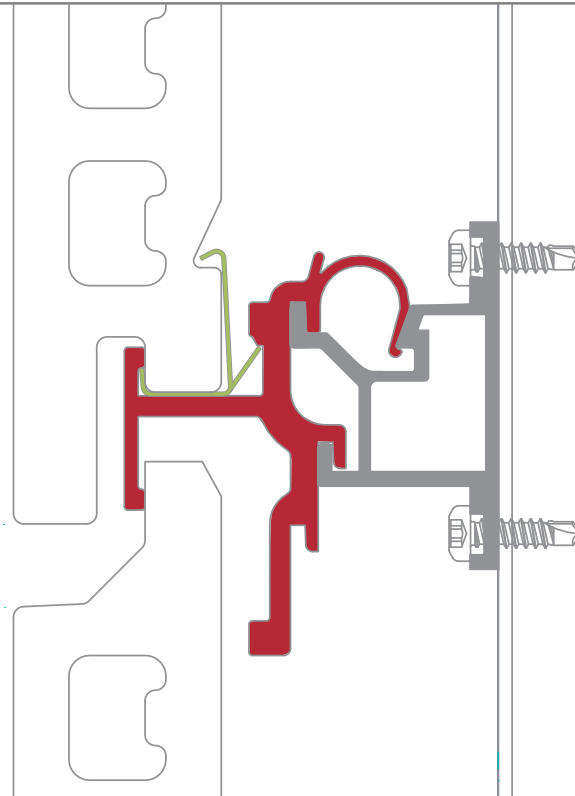

ALPHATON® tile holders

The terracotta tiles are fastened by concealed aluminium tile holders. The holders encompass the head and base ridge and a screw driver is used to click them onto the support profiles. A metallic clicking sound tells the fitter that it has snapped in safely.

The tile holders are designed in such a way that they can be used both on a closed and an open support file. The holder determines the design-engineering 10 mm wide gap between the tile element and the support profile. The M-holder is used in the façade area. For the bottom and top end there is the U and O-holder respectively. For fastening to soffits, special soffit holders are available.

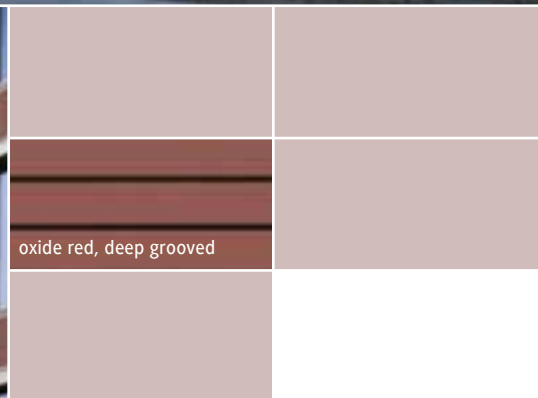

Atlantic Haus, Hamburg
Architects: Herzog und Partner, Munich
with gmp architekten, Hamburg
Colour: oxide red
Surface: deep grooved



Business school, Rheine
Architects: Terhechte und Hoefker, Rheine
Colour: beige
Surface: grooved

ALPHATON® horizontal support profiles

The horizontal support profiles are fastened to conventional vertical profiles with hollow rivets or self-tapping stainless steel screws. In cases where the architecture does not allow support profile span widths bigger than 0.75 m the open support profile Gen. 06 - 75 is used. The total thickness of the façade is then 60 mm. Depending on the foundations and the project-related structural evidence, the open support profile Gen. 06 - 75 can also be installed up to 900 mm wide.

If larger span widths need bridging, the closed support profile Gen. 06 - 150 is used. The maximum possible span width for this is 1,500 mm. The total thickness of the façade is then 70 mm.

The support profile is always arranged in front of the heat insulation, which means this is securely held in place.

The function of the back-ventilation gap is maintained in any event. The permitted projection of the ends of the horizontal support profile beyond the vertical profile makes it particularly cost-effective to design soffits and corners to the building.

ALPHATON® joint profile

Aluminium joint profiles located in the vertical joints prevent panels from rattling in the wind, driving rain from penetrating and in particular the panels from moving sideways and thus guarantee a very exact joint pattern. There are profiles for joint widths of 8 mm, or alternatively 4 mm for the horizontal façade and 12 mm for the vertical façade.

Joint profiles are available both for centre joints and end joints, matching all panel colours.

Vertical basic profiles and wall angle holders

These components are standard in the trade. Their horizontal gap from each other when using the open, horizontal support profile Gen. 06 - 75 is 750/900 mm max., when using the closed support profile Gen. 06 - 150 it is 1500 mm.

Heat insulation

It is possible to choose any thickness of heat-insulation. It is fastened and fixed in position to prevent it swelling and sticking out just by the horizontal support profiles without additional insulation material retainers.

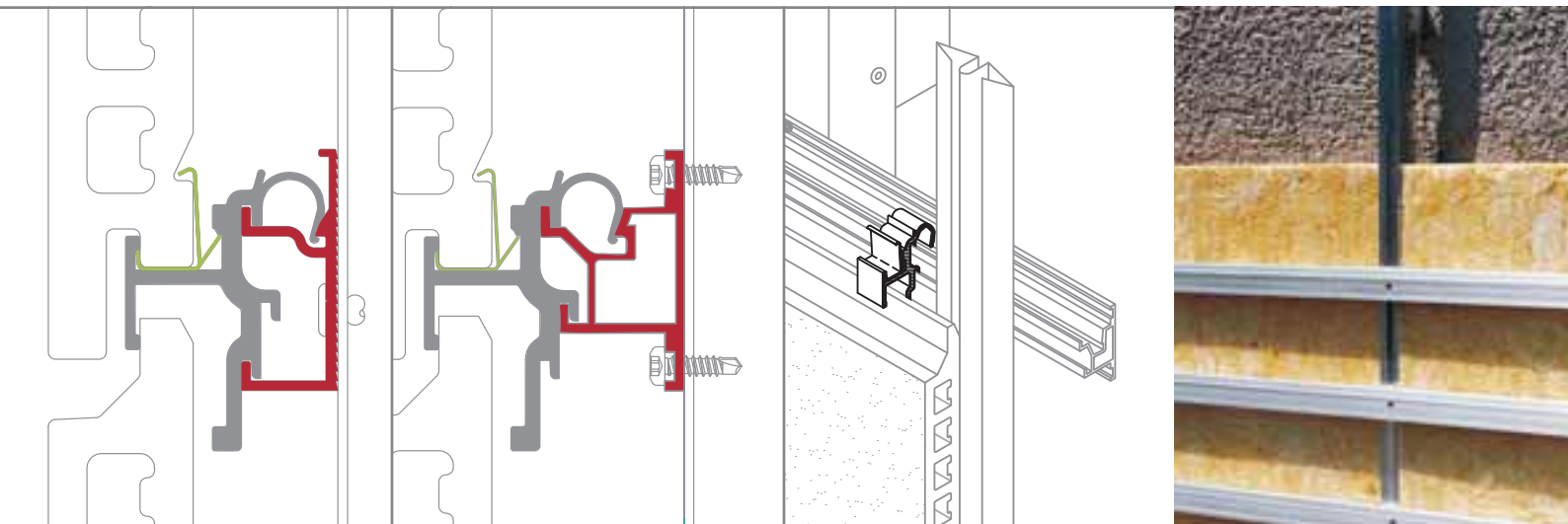

Open horizontal support profile Gen. 06 - 75

Closed horizontal support profile Gen. 06 - 150

Joint profile

Heat insulation



ALPHATON® Gen. 06 - rapid

The patent pending Alphaton terracotta facade system Gen. 06 - rapid opens up whole new options in facade construction.

The tile holders are fitted with a stainless steel spring at the factory. This is inserted into a groove on the reverse side of the panel thus preventing the panel from being taken off unintentionally.

Assembly is done quite differently to the previous method: After assembling the horizontal support profiles, all tile holders for the façade being assembled are clipped in using a screwdriver.

Once the substructure is fully assembled with all tile holders, the terracotta tiles are fitted completely without tools. The stainless steel spring on the tile holder slots into the groove when the panel is fitted and secures the tile. As a result there is no longer any prescribed sequence of installation.

It is possible to start assembling the panels at the top of the scaffolding and to work downwards one floor at a time. This means that the scaffolding can be dismantled one floor at a time.

This considerably reduces the scaffolding costs. Due to the fact that once all panel holders have been fastened, only the panels need assembling, the installation time is reduced.

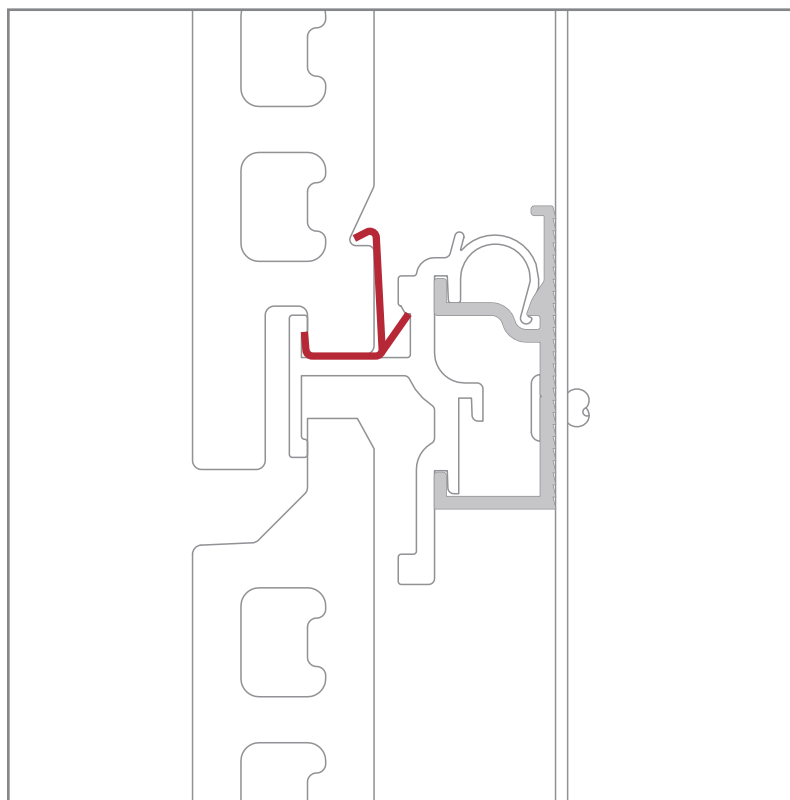



Radlicka (CZ)

Architects: Ateliér Krátký, Vladimír Krátký, Prag

Colour: vulcano grey

Surface: standard

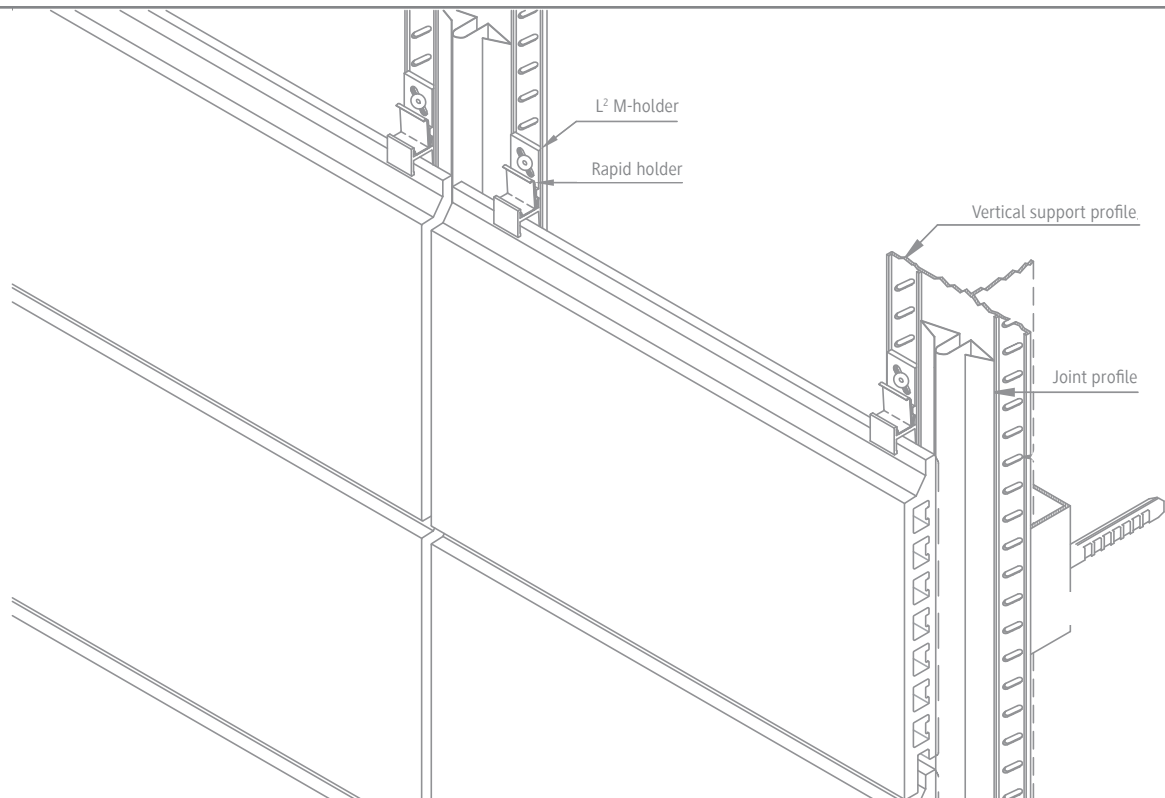

ALPHATON® façade system L²

The ALPHATON® façade system is made out of four simple basic components:

- Terracotta tiles
- Tile holders
- Vertical support profile
- Joint profile

ALPHATON® terracotta tiles

The extruded MOEDING ALPHATON® terracotta tiles are produced mainly from domestic clay and are fully imbued with colour. Due to the very high firing temperature and the long firing period, intensive colours and the best strength are achieved.

The terracotta tiles are double-walled and 30 mm thick. The breaking loads of the ALPHATON® panel are therefore many times higher than with single-walled panels. The shape of the panel holders also contributes to the stability of the whole façade design. The panel holders are formed in such a way that frontal forces are transferred to the whole tile thickness and dissipate into the substructure.

The specifications for this are the so-called ball-throw test and the CWCT accreditation, which is generally applicable in England and is already part of the standards there.

Moeding L² vertical profile

In the curtain wall, back-ventilated tile façade, there is an emerging trend for increasingly longer tiles. In the meantime ALPHATON® tiles can be supplied up to a length of 1500 mm. There is a building inspectorate approval for this.

A vertical substructure system is the most economical solution with such large tile lengths. So far only standard T profiles or pre-drilled T profiles were used. The disadvantage of standard T profiles is that a hole must be drilled in the T profile for each individual tile holder. This is a time consuming and expensive work. There is no requirement for drilling in the T profiles that are pre-drilled at the factory, but the profiles must be aligned very precisely to ensure that the provided grid dimensions of the façade can be achieved in the profile section joints. This alignment is in turn time consuming and expensive. Both the above-mentioned solutions are not ideal.

For this reason MOEDING has developed the vertical L² substructure systems. The system consists of the components L² support profile, L² tile holder, L² rivet and the joint profiles.

The highlights of the L² substructure system are the diagonally running slots on both sides of the vertical L² support profile and the L² tile holders. The slots in the L² tile holders run counter to those in the L² support profile. The L² tile holders can be fixed through these slots without pre-drilling by means of the rivet on the L² support profile. Thus a continuously variable millimetre adjustment of the axis height is possible. By the use of a simple gauge in the axial dimension of the tiles, the assembly of the L² tile holders is done very quickly and accurately. An exact alignment of the L² support profiles to the grid dimension of the façade is not required.

A stainless steel rivet specially suited for slots is required for the reliable fastening of the L² tile holder on the L² support profile. This L² rivet is a component of the L² substructure system.

The already known and proven Rapid System is also used in the L² substructure system. Thus all L² tile holders can be fixed on the L² bearing profile before proceeding with the tile installation.

As a final assembly step, the tiles are simply suspended in the L² tile holders and they lock into the Rapid spring integrated in the holders. Tools are not required to suspend the tiles.

Thereby much installation time is saved.

A building inspectorate test certificate, a structural standard and detailed drawing are available for the L² substructure system.

The MOEDING L² system in brief:

- Fast installation
- Pre-drilling of the support profiles not needed
- Precise alignment of the vertical support profile to the axial dimension of the façade not needed
- Building inspectorate test certificate available
- Structural standards available
- Rapid System is a component of the L² substructure system

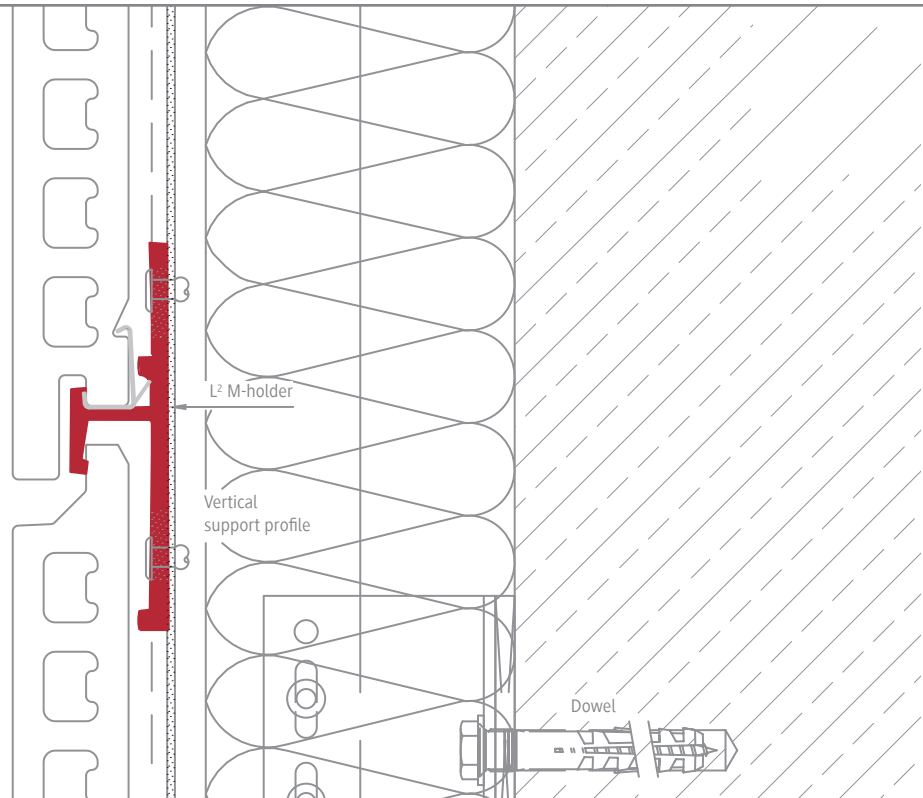

ALPHATON® tile holders

The terracotta tiles are fastened by concealed aluminium tile holders. The holders encompass the head and base ridge and are fixed by the L² rivet to the vertical L² profile. A metallic clicking sound tells the fitter that it has snapped in safely.

The holder determines the design-engineering 10 mm wide gap between the tile element and the support profile. The M-holder is used in the façade area. For the bottom and top end there is the U and O-holder respectively. For fastening to soffits, special soffit holders are available.



West Kowloon Station, Hong Kong
Architects: Aedas, HK-Quarry Bay
Colour: brick red
Surface: standard, grooved

ALPHATON® support profiles

The vertical support profile is fixed on wall angle holders which are anchored directly in the support wall.

ALPHATON® joint profile

Aluminium joint profiles located in the vertical joints prevent panels from rattling in the wind, driving rain from penetrating and in particular the panels from moving sideways and thus guarantee a very exact joint pattern. There are profiles for joint widths of 8 mm, or alternatively 4 mm for the horizontal façade and 12 mm for the vertical façade.

Joint profiles are available both for centre joints and end joints, matching all panel colours.

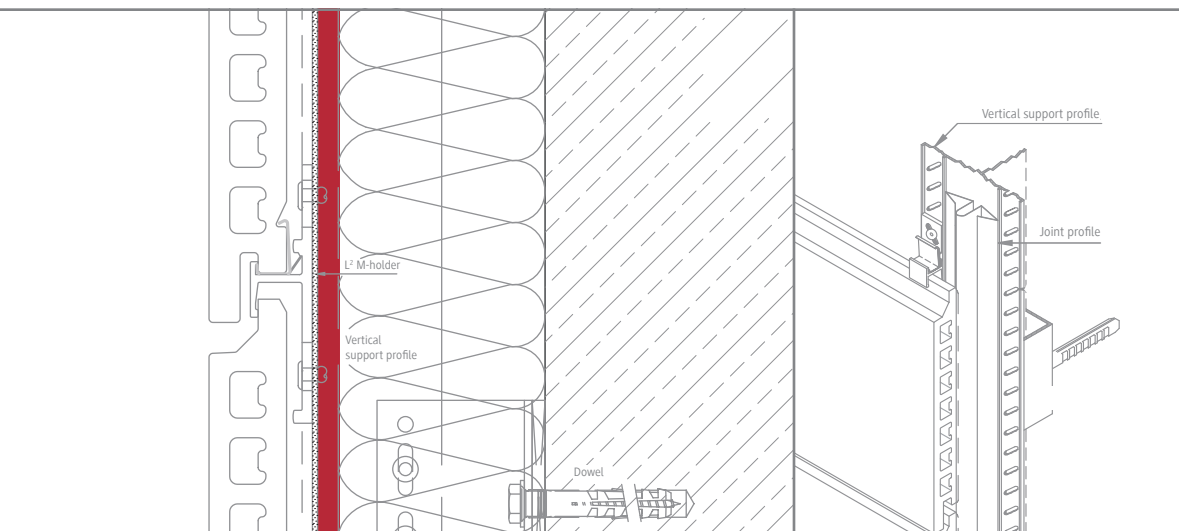

Vertical support profile

Joint profile

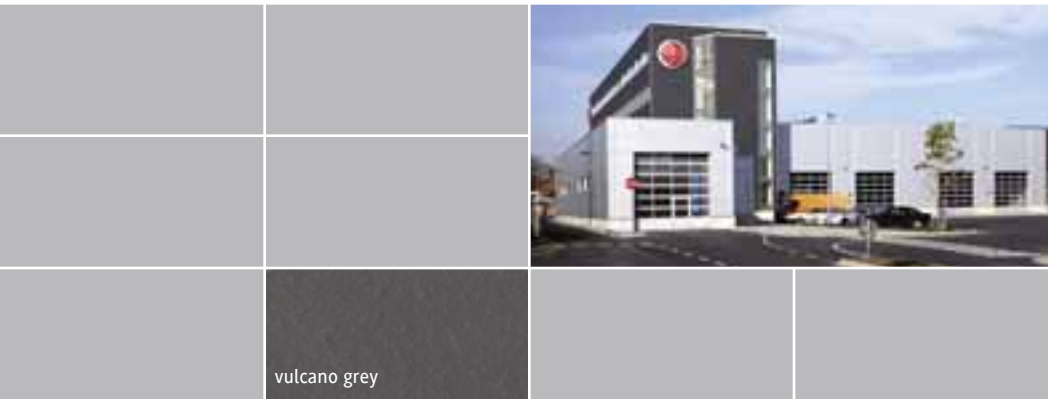

ALPHATON® L² - rapid

This patent-pending system opens up whole new options in façade construction.

The tile holders are fitted with a stainless steel tongue at the factory. This is inserted into a groove on the reverse side of the panel thus preventing the panel from being taken off unintentionally.

Assembly is done quite differently to the previous method: After assembling the horizontal support profiles, all tile holders for the façade being assembled are clipped in using a screwdriver.

Once the substructure is fully assembled with all tile holders, the terracotta tiles are fitted completely without tools. The stainless steel tongues on the tile holder slots into the groove when the panel is fitted and secures the tile. As a result there is no longer any prescribed sequence of installation.

It is possible to start assembling the panels at the top of the scaffolding and to work downwards one floor at a time. This means that the scaffolding can be dismantled one floor at a time.

This considerably reduces the scaffolding costs. Due to the fact that once all panel holders have been fastened, only the panels need assembling, the installation time is reduced.

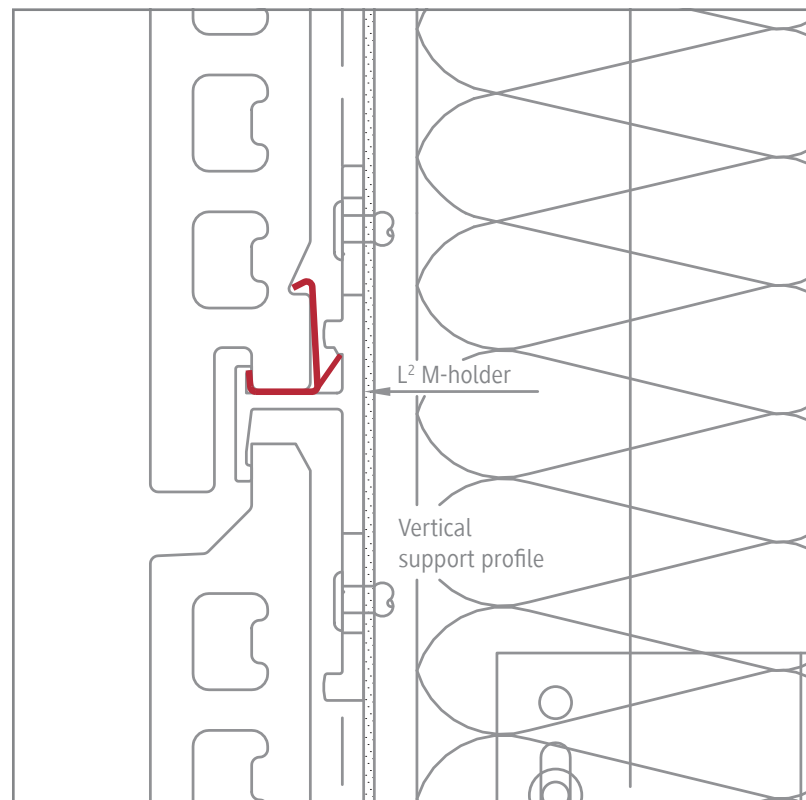



Osnabrück bus depot
Architects: agn GmbH Paul Niederberghaus & Partner,
Ibbenbüren
Colour: vulcano grey
Surface: standard

The back-ventilated and heat-insulated façade – the ideal design principle for external walls

Dividing the physical and technical building functions and allocating them to the different layers of the wall design, results in the following benefits:

- Much lower heat loss
- Reliable heat protection in summer
- Effective weather protection and specific wicking of moisture
- Simple planning and assembly

Due to its optimum material properties, the MOEDING façade system offers these benefits in addition:

- Resistant to all kinds of aggressive environmental influences
- Attractive patination
- Long life span and high cost-effectiveness
- Can be universally applied in new construction and when renovating old buildings
- High architectural design quality

The back-ventilated and heat-insulated façade in modern wall construction

The monolithic wall design meets the structural requirements on contemporary designs or old building renovations only with restrictions. The back-ventilated façade is quite different, as in this case the different functions are strictly divided and are each allocated to separate components. In this way each function can be optimised in its own right:

- The supporting wall bears the static loads.
- The heat insulation is correctly located in building physics terms.
- The substructure for the façade cladding transfers its own weight and any wind loads. Vaporous damp from the home diffused outwards and building moisture on new constructions, as well as penetrating water are reliably dissipated by the back-ventilation.
- And finally the façade cladding acts as a barrier to driving rain for the insulating material and substructure and above all as a design element.

Back-ventilation

The back-ventilation acts to dissipate the moisture that diffuses through the wall of the building. This takes place via a 4 or 9 cm deep gap between the façade panels and the heat insulation. At the same time it acts as a heat shield in summer, as a build-up of heat behind the façade is prevented. To ensure capillary separation, a 10 mm deep gap is also arranged between the façade elements and support profile (according to DIN 18 516 Part 1 at least 5 mm is required). This means that the condensate can flow freely away on the reverse side of the façade elements. Substructure and heat-insulation stay dry.

Ventilation

The ventilation cross-sections are also much bigger than specified in DIN 18 516 Part 1. The ALPHATON® terracotta façade has a 5 mm wide horizontal joint gap on every façade element. Ventilation openings at the bottom and top of the façade are not necessary therefore. Furthermore there is pressure compensation across the joints so that wind forces can be quickly dissipated.

Heat insulation

The mineral fibre heat insulation is arranged between the basic profiles or basic battens and is prevented from swelling or sticking out by the horizontal support profiles. This ensures that the ventilation gap in front of the support profiles cannot be blocked off at all, thus guaranteeing that the back-ventilation always works perfectly.

Directing water away

On the horizontal façade, the drip and end bead on the façade elements ensure that water is directed to the outside of the façade. On the vertical façade the water is directed away by the vertical perforation.

Noise insulation

The protection against air-borne noise through walls is significantly improved by the ALPHATON® terracotta façade. For a 24 cm KSV wall plastered on one side with noise insulation $RW = 55$ dB, the improvement is 9 dB, which makes the calculated value $RWR = 62$ dB according to DIN 4109 (test report on request).

Fire protection

All components in the ALPHATON® terracotta façade on aluminium substructure are not flammable (building material class A). Fire resistance F 90 has been proven for the design. The spread of fire is prevented by the horizontal support profiles, which act as a fire block. This means the façade can be used in all German states and throughout Europe even on special constructions without height restriction and without additional conditions.

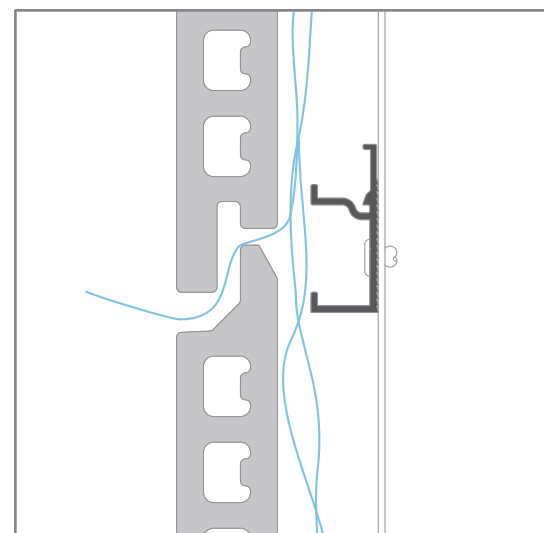

Back-ventilation

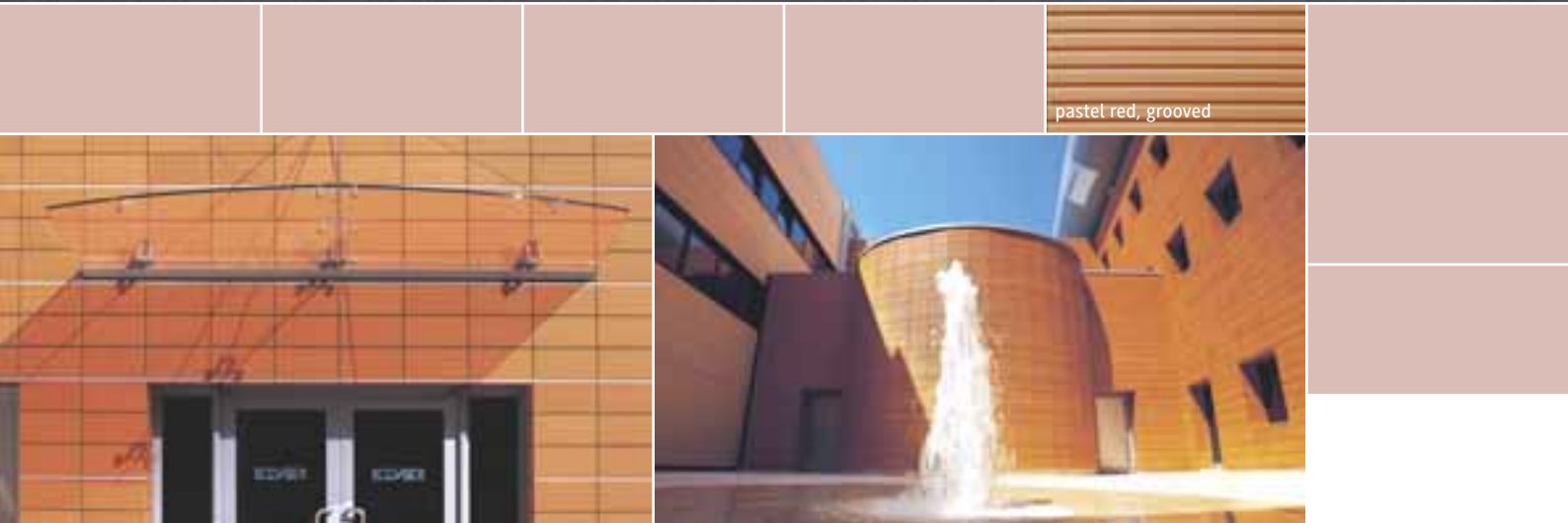

pastel red, grooved

Elvox office building, Padua, Italy
Architects: Prisma Engineering s.r.l., Padua, Italy
Colours: pastel red
Surface: grooved

Planning and tendering

For planning ALPHATON® horizontal and vertical façades, an extensive collection of tried and tested connection details with many suggestions is available and for submitting telling sample contract specifications for tender.

The so-called detail booklet especially put together for detailed solutions gives planning tips and also shows very individual transitions from the façade to other building materials or technical designs.

Four detailed solutions are listed below as an extract. As early as the planning stage, it is important to look for solutions. Our maxim is therefore:

You plan it, we will take care of how to implement it.

Service and advice

At MOEDING this means:

- Comprehensive help in planning
- Technical support at the planning and building stage
- A strong field and office sales team
- Competent sales partners in more than 60 countries

We fulfil the planner's needs.

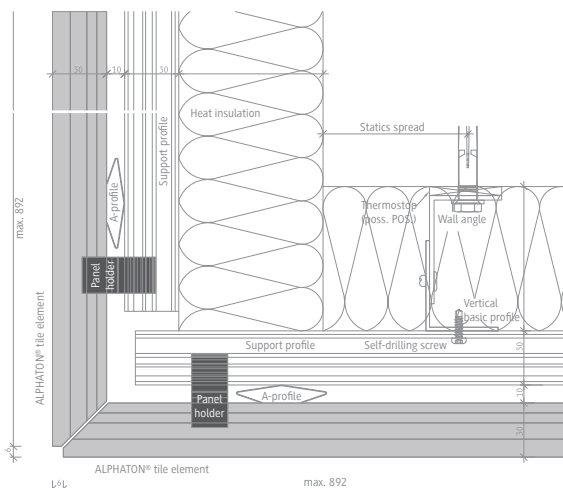

Tile external corner Gen.06 150

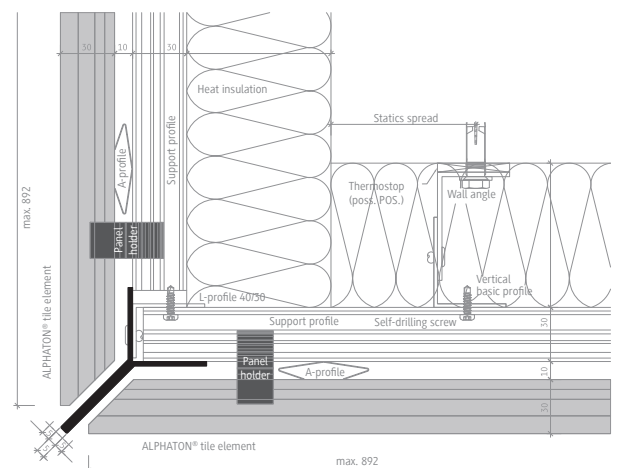

Metal external corner Gen.06

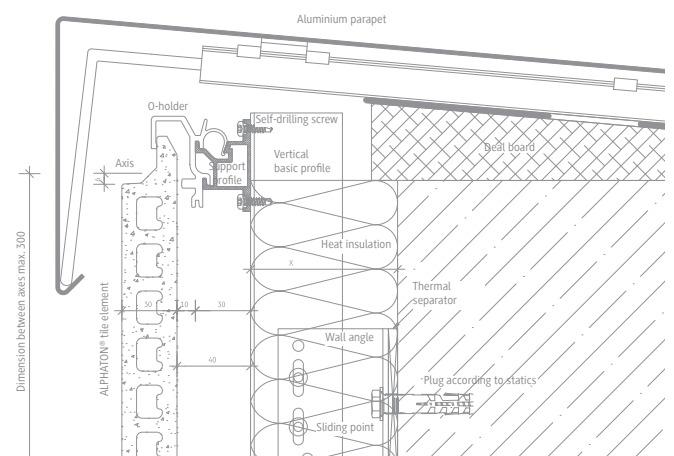
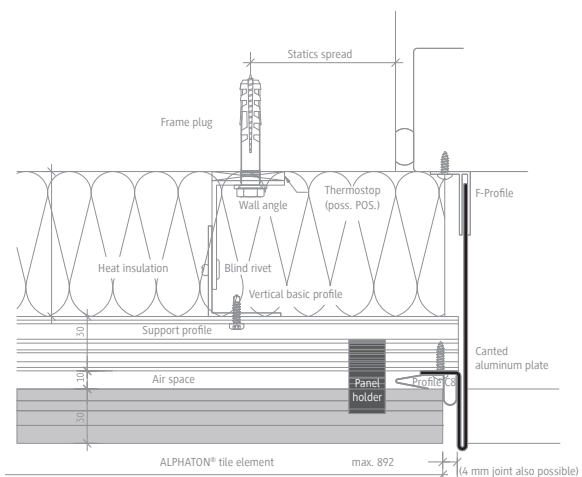

Gen. 06 150 metal window soffit

Flat roof bargeboard Gen. 06

Wolfsburg hospital

“Haus G” new building and main corridor
 Consortium: Koller Heitmann Schütz, Wolfsburg
 Rauh Damm Stiller Partner, Hattingen
 Colour: sand
 Surface: sanded

Fascinating variety

With the curtain wall, back-ventilated tile façade system ALPHATON® from MOEDING, you obtain creative tools to perfectly implement your ideas of design and function. There are 18 standard colours of the façade tiles to assist you – all original colours of the ceramic material.

The surface structure offers a variety of variations: You can for instance use ground, brushed or fired tile surfaces to create more exciting visual effects on the façade. The glazed surfaces in the form of bands or ornaments are particularly eye-catching.

Many surfaces and colours tempt one to experiment. With the ALPHATON® special shapes, such as baguettes and lamella, you can ideally connect more features and ideas with one another. Take advantage of the vast designing potentials of the MOEDING ALPHATON® façade system.

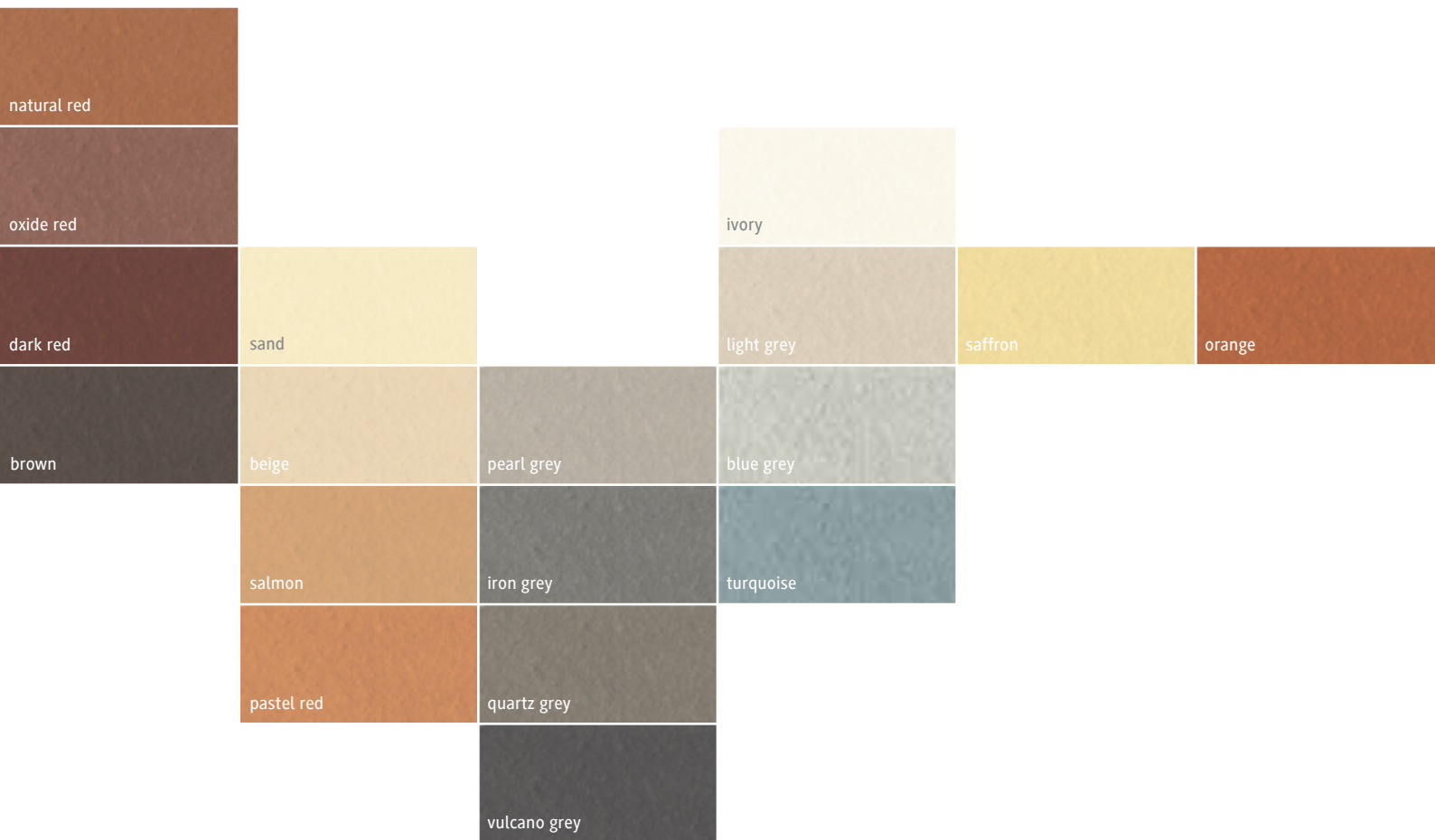

Material and colours

Thanks to its ideal properties, the traditional terracotta material suits new and historic architectural shapes. It ages over decades with a fine patina. The façade elements can be supplied in the 18 standard colours available.

Special colours are possible on request. All colours are the true colour of the terracotta body, so that neither side-cuts nor damage to the surface are able to reveal a different coloured looking body.

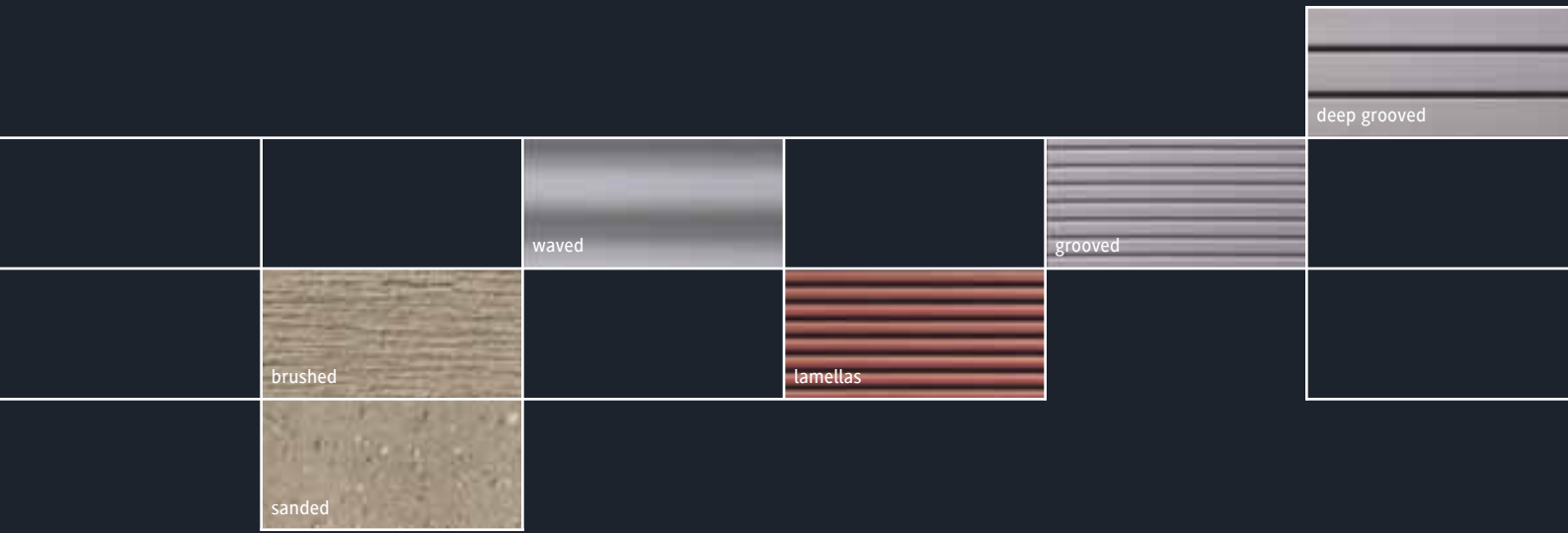

Surfaces

Besides the standard version, you can also get all colours smooth with brushed with lightly textured surface.

For a more eye-catching look there are grooved, deep grooved and waved panel surfaces. The combination of light and shadow results in visually 3-dimensional impressions.

Another example is the lamella panel, which is also available in a perforated version to give an individual backlighting effect.

On special request we design surface textures with a particular architectural quality.

Glazed surfaces

The ALPHATON® terracotta façade also comes with a glazed panel surface.

The brilliant sheen forms a particular appeal, which has an effect on the whole façade, but also comes with individual features such as bandings, ornaments or individual patterns which grab the onlooker's attention.

The glazed tile elements can be combined with all other ALPHATON® system components can be combined.

- Brilliant colouring
- Dirt-repellent
- Other colours are possible

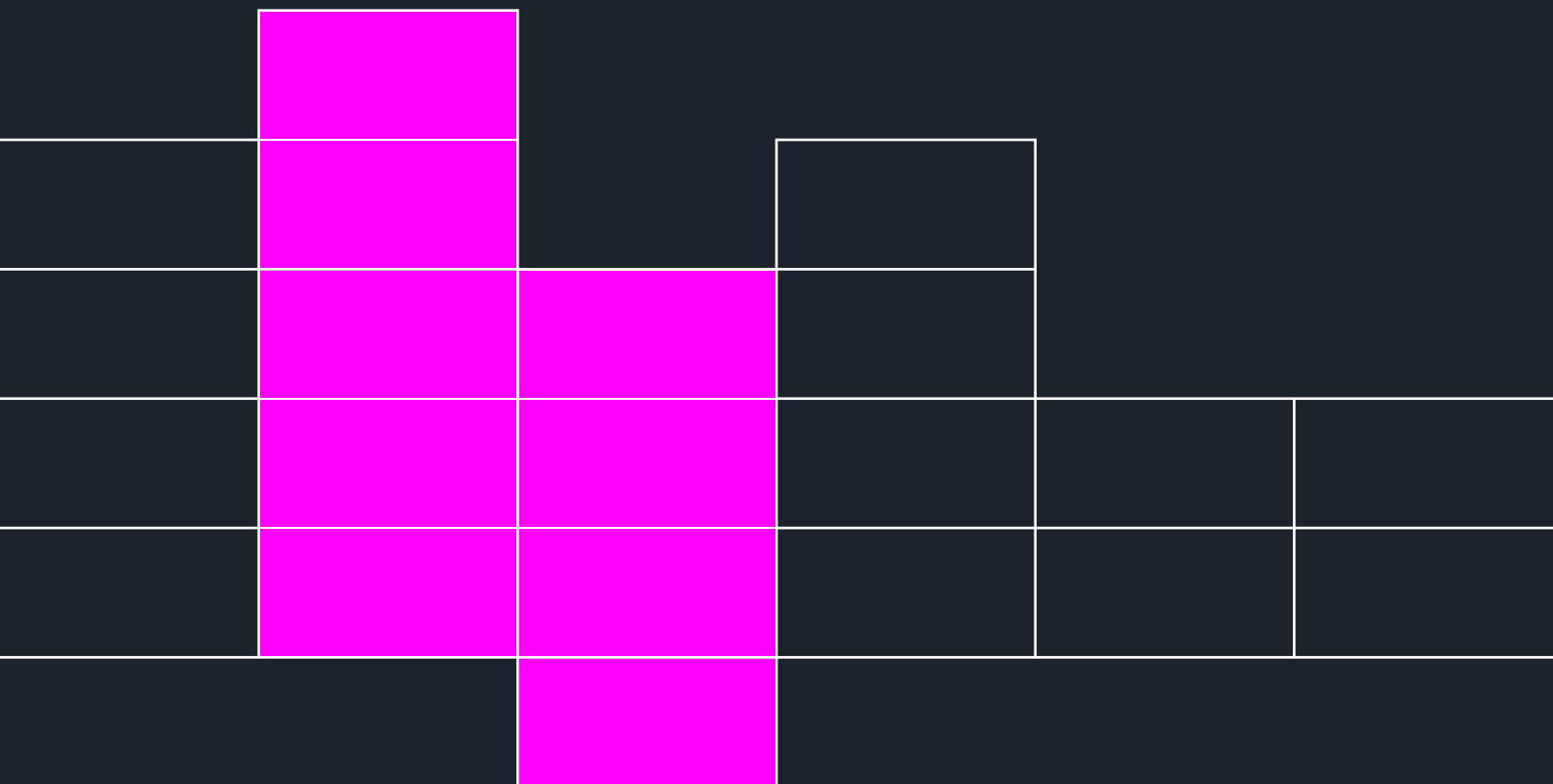

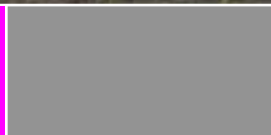

FEBO office building, Amsterdam, Netherlands
New construction
Colour: black
Surface: glazed

Sunscreen and blinds

The baguettes and lamellas in the ALPHATON® façade system on the one hand provide creative freedom, whilst on the other hand, function and uses are stylishly adopted to the architecture.

The use of MOEDING shading and sunscreen elements keeps the unity of the structure visible. An unnecessary and awkward mixture of building materials is therefore easily circumvented.

The baguettes and lamellas can be produced in different dimensions and wall thicknesses.

The formats can be easily transferred to the façade pattern and can be produced afterwards for each project.

Finished parts can be prefabricated from several baguettes.

Baguettes are used as an additional design element for façade details:

- Windows
- Ventilations outlets
- Air conditioning
- Passageways
- Outdoor corridors
- Stairways
- Balcony areas
- As a blind and/or light shield in front of glass

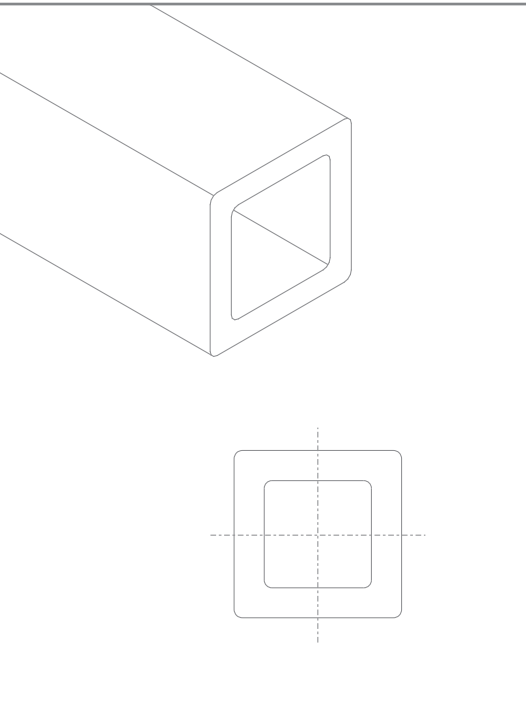

Baguette

Lamella profile

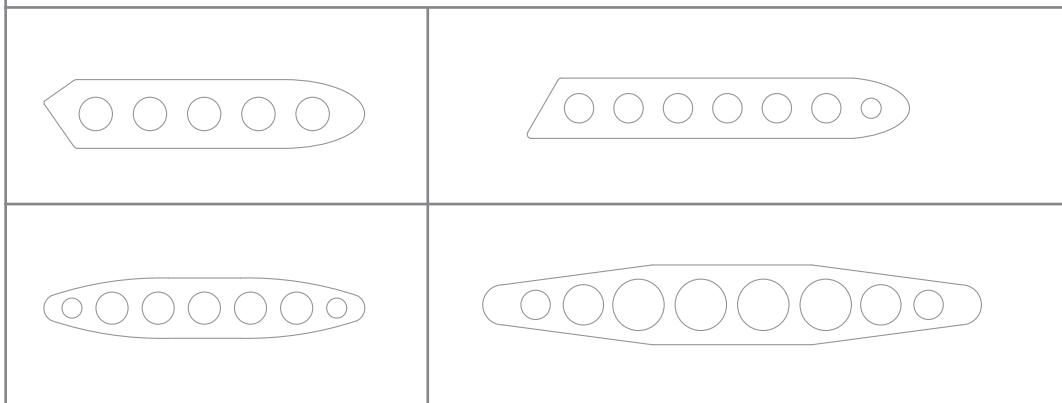

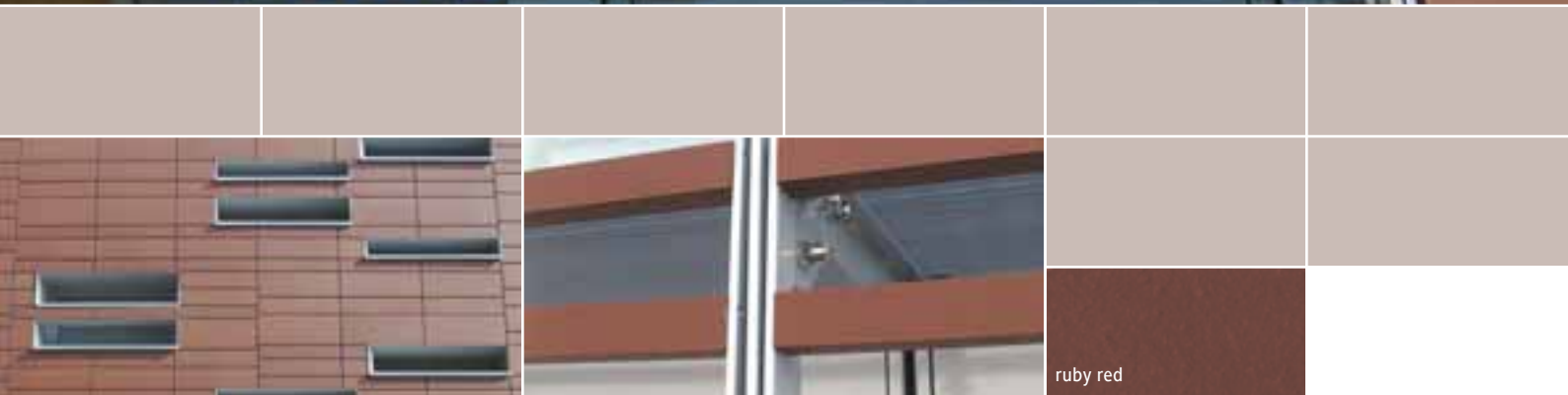

Centro Direzionale Dal Negro, Treviso

Architects: Studio Ingegneria Tiziano Bonato di Treviso + Fabrizio Fontana, Padua

Colour: ruby red

Special form: baguette

Surface: standard

Formats and axial dimensions – ALPHATON®

There is a broad range of design options thanks to the choice between horizontal and vertical formats, depending on whether a building will be accented horizontally or vertically.

ALPHATON® tile is available in 12 different standard formats, from 150 to 400 mm, and in lengths of up to 1500 mm.

Special formats are possible:

ALPHATON® terracotta elements are available in lengths up to 1,500 mm.

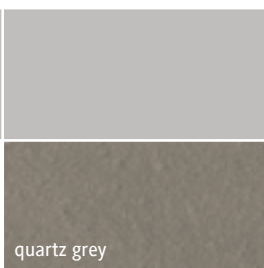
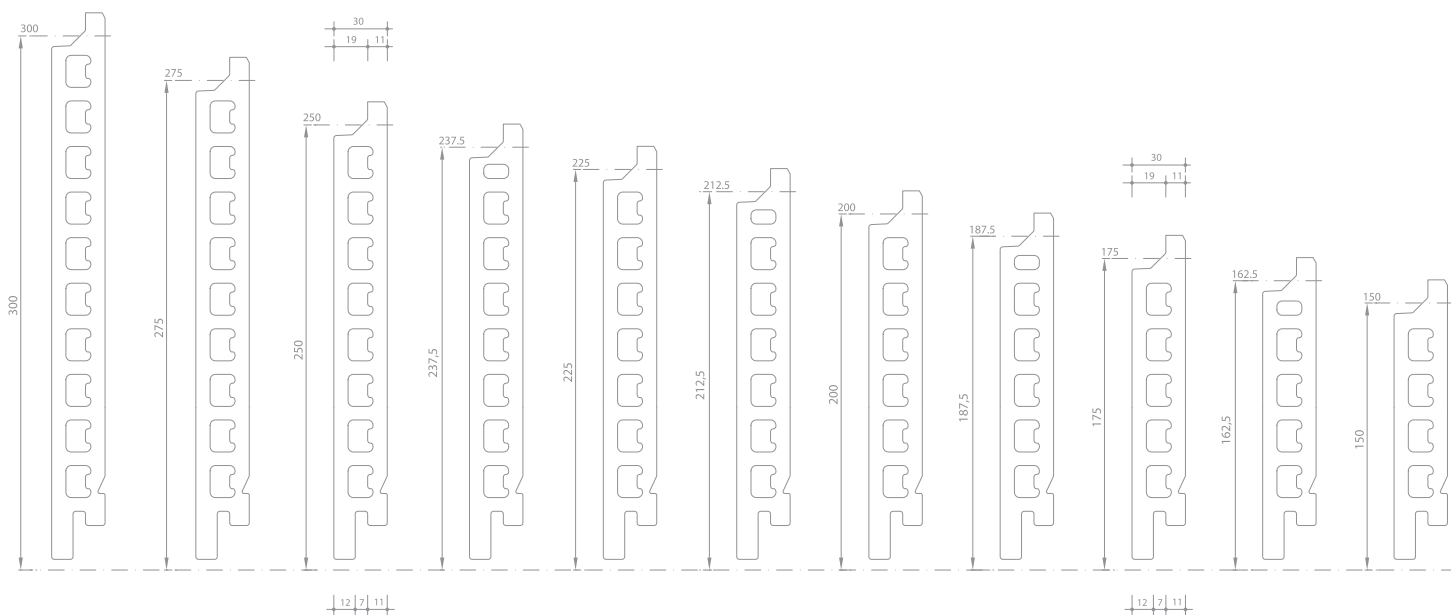



Fire and rescue station, Hagen-Hohenlimburg
Architects: Kamel Architekten und Ingenieure, Hagen
Colour: quartz grey
Surface: standard



pearl grey



Detached house, Ealing, West London, GB
Architects: Burd . Haward . Marston, London, GB
Colour: pearl grey
Surface: standard

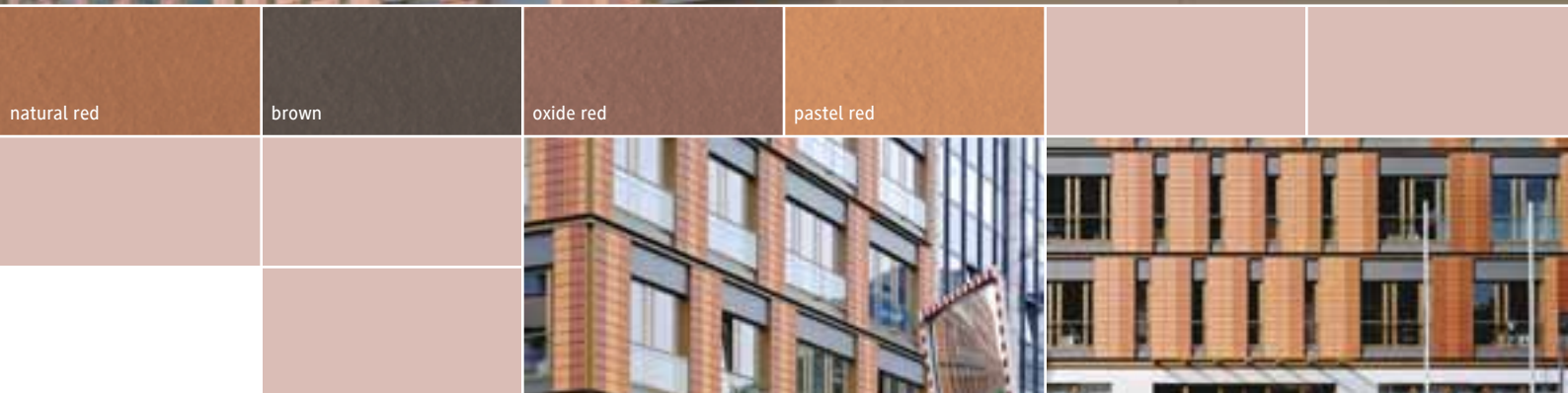

Service, flat and office building City West, Frankfurt
Architects: Kölling Architekten, Bad Vilbel
Colours: brown, oxide red, natural red, pastel red
Surface: standard

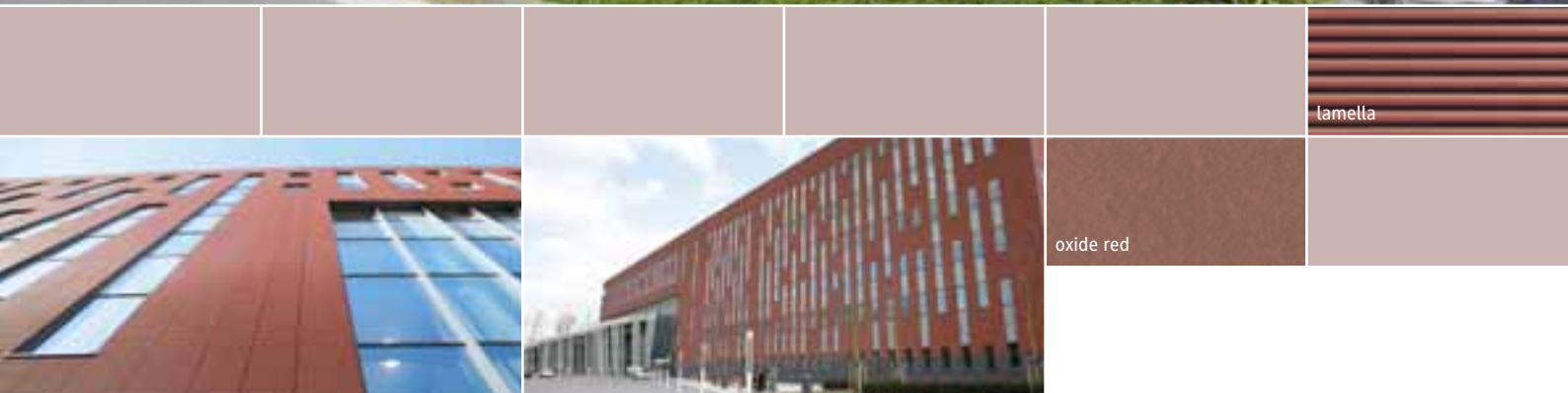

Avans University, Breda
Architects: Tilburg, Ebelings, von Behr,
Capelle aan den IJssel Rienks Architecten, Breda
Colour: oxide red
Surface: lamella panel

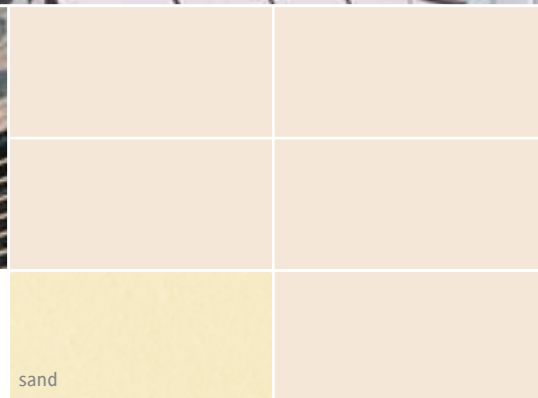

Office and commercial building, Buttergasse/Alter Markt, Magdeburg
Architects: ACM Architekten, Magdeburg
Colour: sand
Special form: baguette
Surface: standard

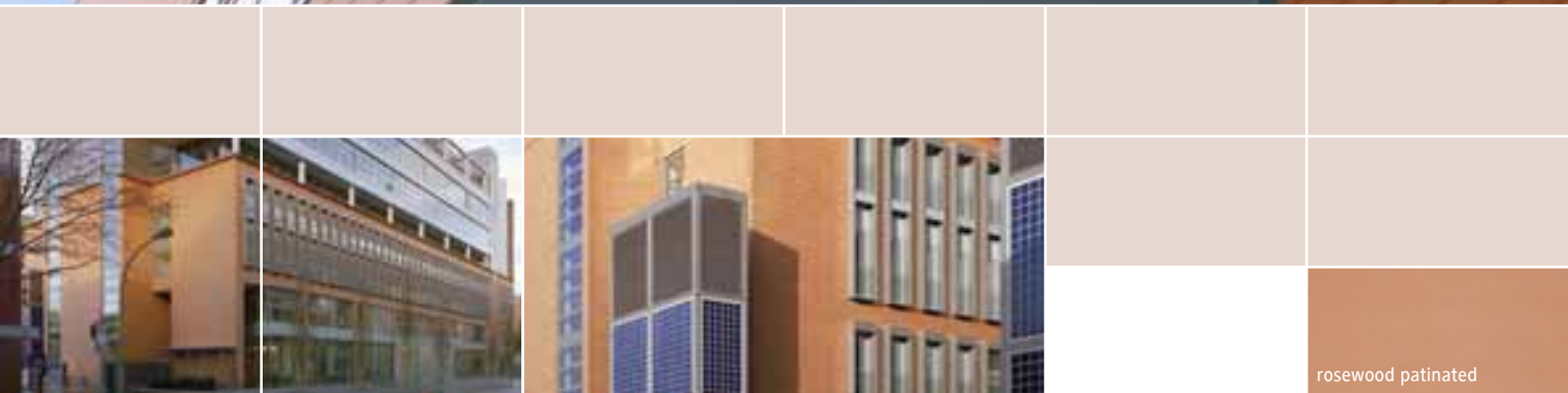

Mainova AG, Frankfurt
Architects: KuP Kleinert und Partner, Frankfurt
Colour: rosewood patinated
Surface: standard



Special colour



Town Hall Gallery, Leverkusen
Architects: HPP, Dusseldorf
Special colour
Special surface + baguettes



Town Hall, Verl
Architects: Schlattmeier Planungs GmbH, Herford
Colour: vulcano grey
Surface: standard

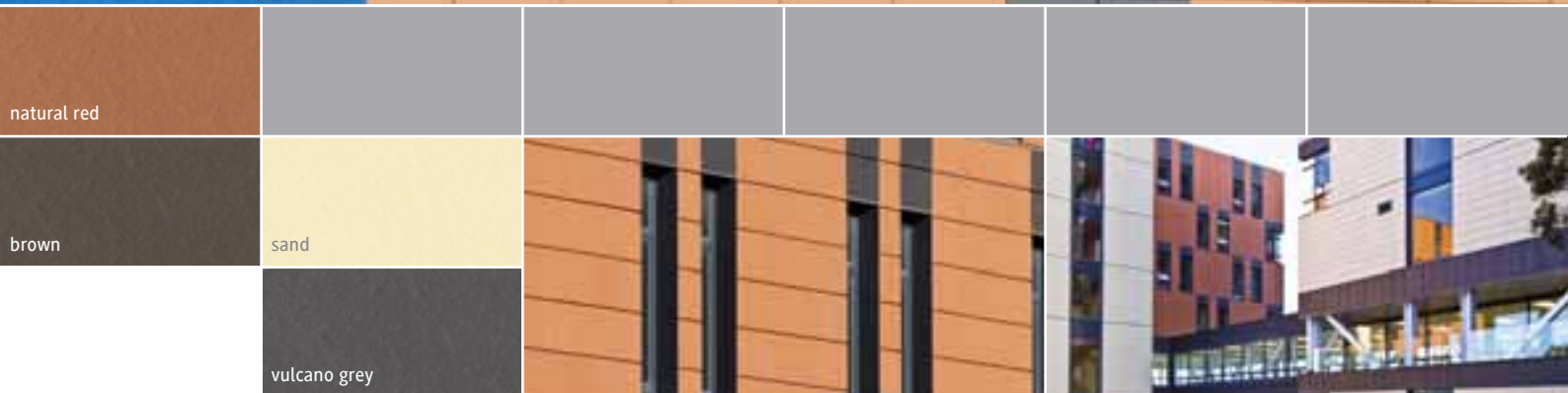

VUW Campus, Wellington, NZL
Architects: Frank Coleman Architects, Auckland, NZL
Colours: natural red, brown, sand, vulcano grey
Surface: standard

Textil-Autowäsche Fahrzeug-Innenreinigung

unkt, wäscht mit Rabatt



pastel red

Mr. Wash, Stuttgart

Architects: Derichs + Waldow Architekten, Dusseldorf

Colour: pastel red

Surface: standard

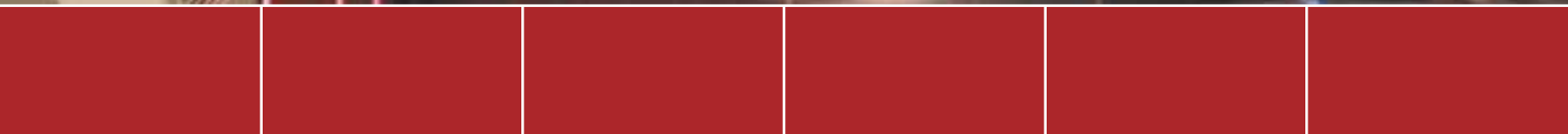

MyZeil shopping and leisure centre, Frankfurt
Architects: Massimiliano Fuksas Architekten, Rome
Colour: red
Surface: glazed, grained special surface

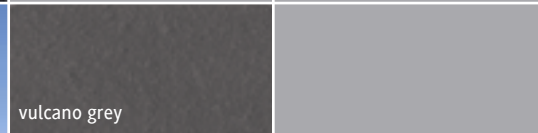

Akershus University Hospital, Oslo, NOR
Architects: C.F. Moller, Arhus, Denmark
Colour: vulcano grey
Surface: standard
Special form: baguette

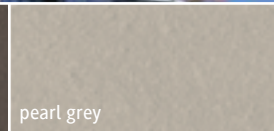
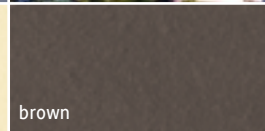
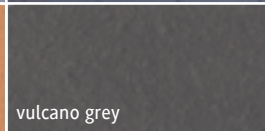
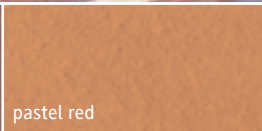
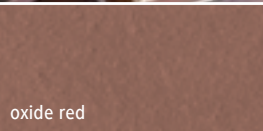

oxide red

pastel red

vulcano grey

sand

brown

pearl grey

AT Amsterdam

Architects: Hans van Heeswijk architecten, Amsterdam

Colours: oxide red, pastel red, vulcano grey, sand, brown and pearl grey

Surface: standard

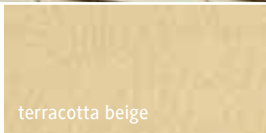

terracotta beige

Premier Inn, Doncaster, GB
Architects: Cartwright Pickard, GB
Colour: terracotta beige
Surface: standard
Special form: clapboard

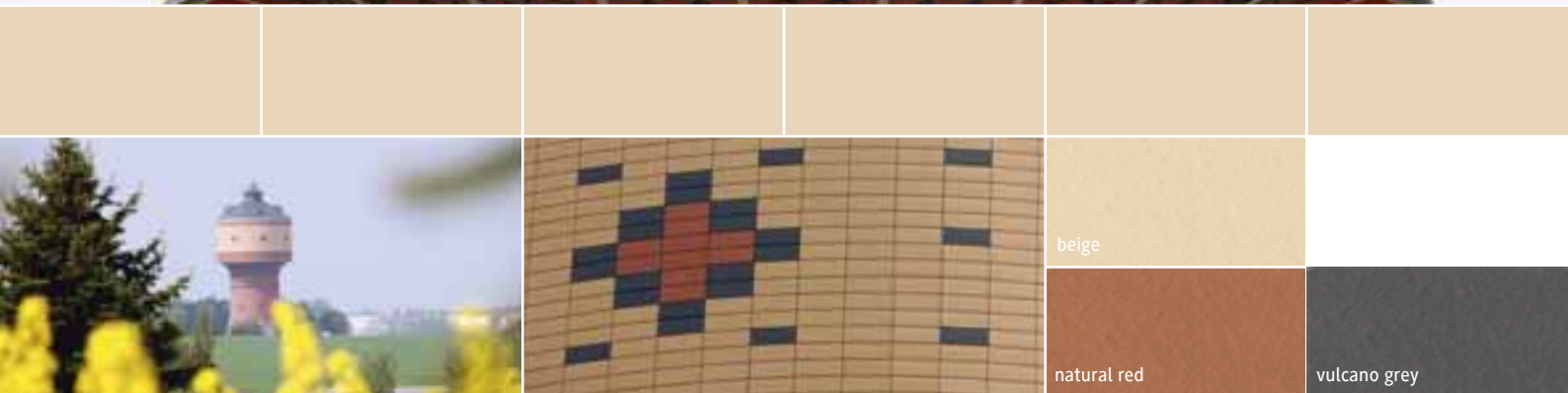

Water tower, Mittweida
Architects: bks Ingenieurbüro für Hochbau, Wilkau-Haßlach
Colours: beige, natural red, vulcano grey
Surface: standard



natural red patinated



Putney Bridge, London, GB
Architects: Patel Taylor, London, GB
Colour: natural red patinated
Surface: standard



Alter Hof (recessed balconies), Munich
Architects: Auer + Weber + Architekten, Munich
Colour: natural red
Special form: Tile baguettes with triangular cross-section

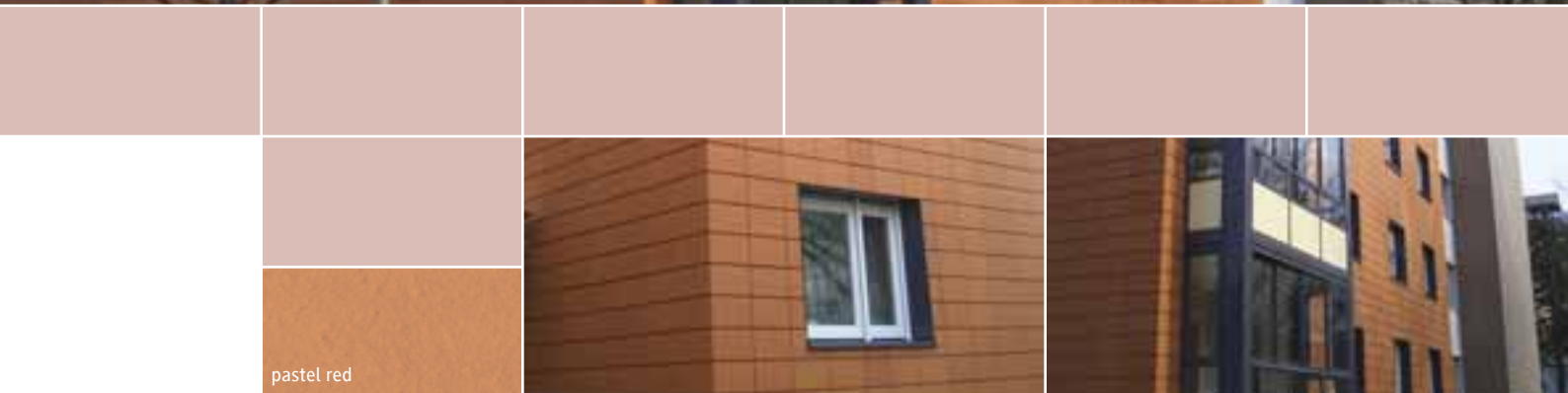

Public housing, Karlsruhe
Architects: Archis, Karlsruhe
Colour: pastel red
Surface: standard



Turnierstieg flat building, Hamburg
Architects: Holger Trumpf, Hamburg
Colours: natural red, beige, pearl grey
Surface: standard

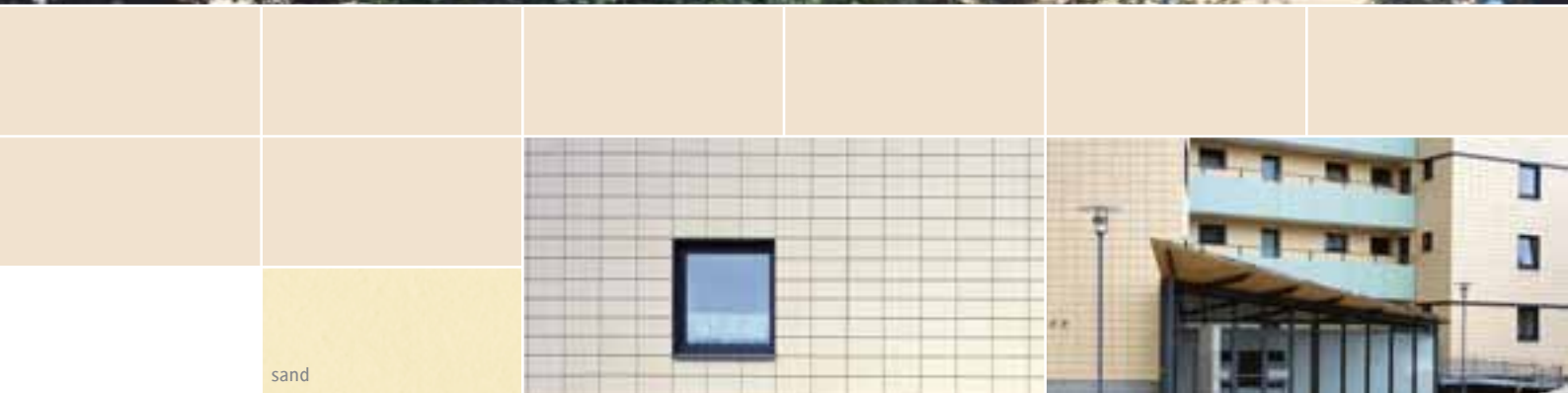

sand

Residential high-rise, Bremerhaven
Architects: STÄWOG, Bremerhaven, H.-J. Ewert
Colour: sand
Surface: standard

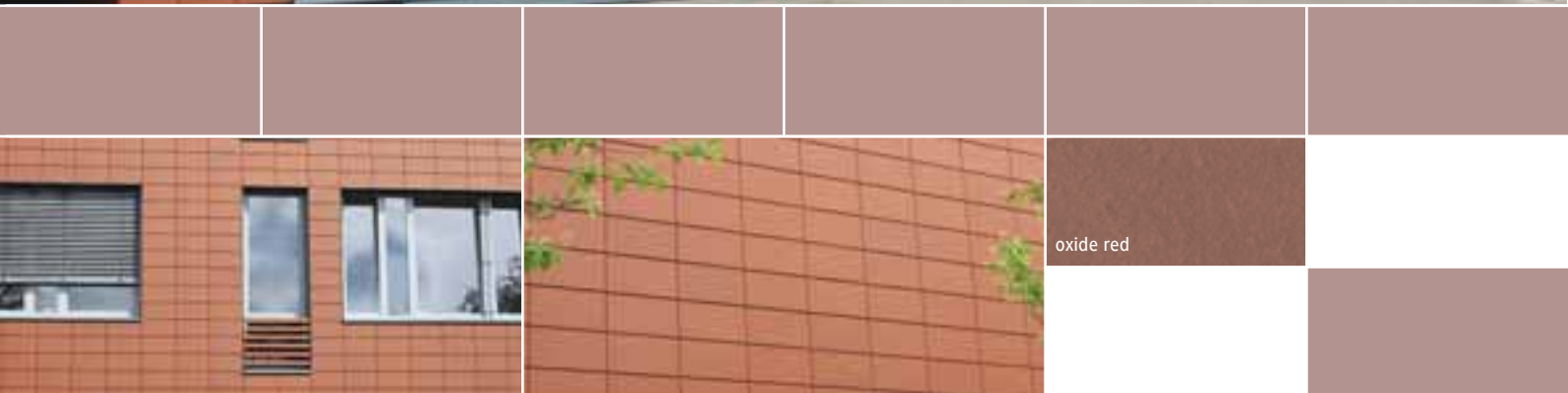

Couven Gymnasium, Aachen
Architects: Finkeldei Architekten, Linnich
Colour: oxide red
Surface: standard, grooved
Special form: baguette



salmon

Haus Windhuk, Westerland
Architects: Schlums und Franz, Westerland
Colour: salmon
Surface: standard

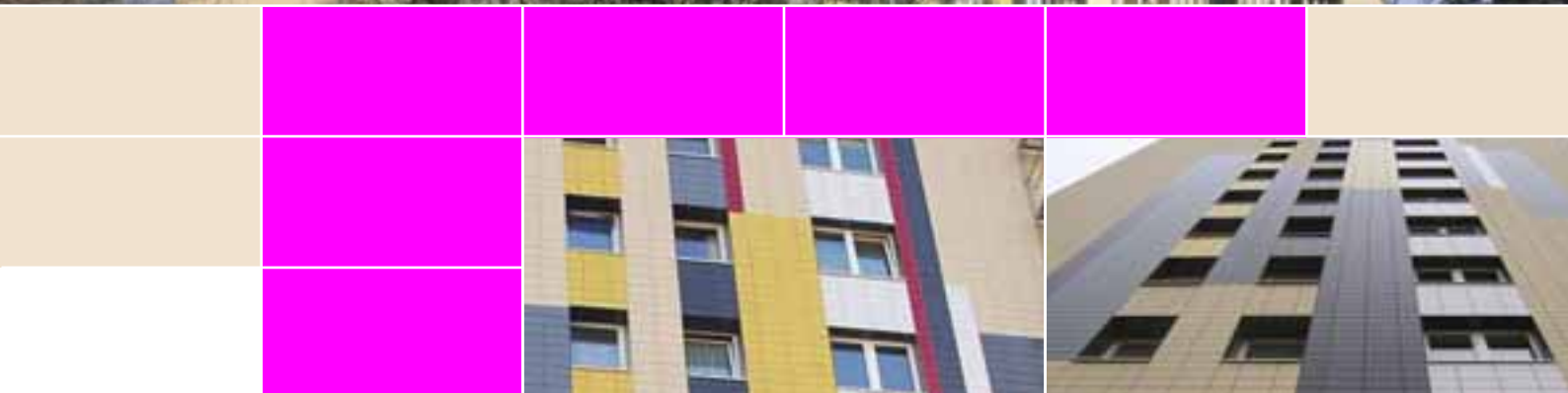

Försterweg, Hamburg

Architects: Hans Rau, Hamburg

Colours: yellow, red, black, grey, dark grey, white

Surface: glazed



Before

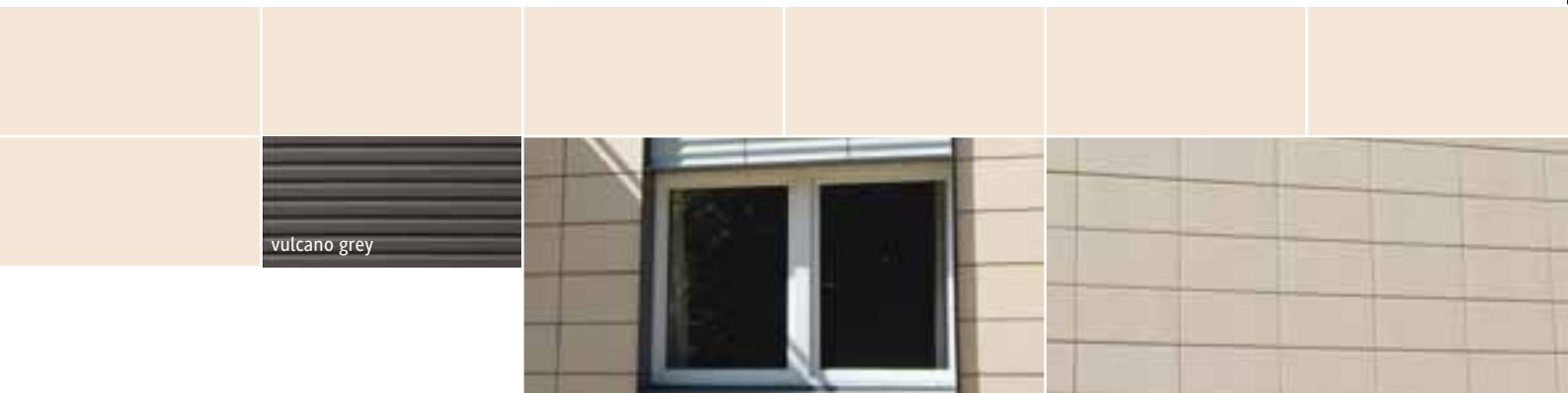

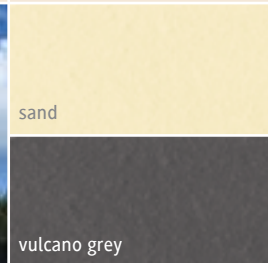
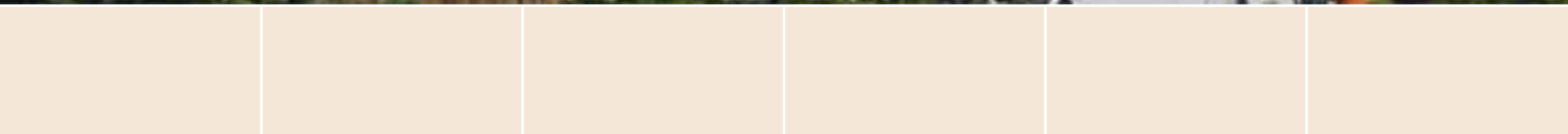

High-rise Waldstrasse, Sylt
Architects: PGB Projektentwicklungsgesellschaft + Bauplanung, Hamburg
Colours: vulcano grey and sand
Surface: standard, grooved

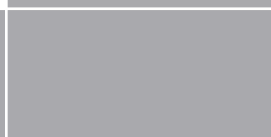
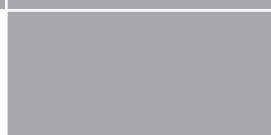
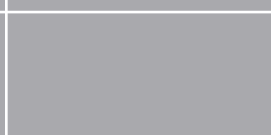
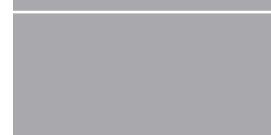

Moeding Keramikfassaden GmbH
Ludwig-Girnguber-Straße 1
84163 Marklkofen
Germany
Fon +49 (0) 87 32/246-00
Fax +49 (0) 87 32/246-69
Internet: www.moeding.de

